

## Product Facts

- Designed to be the lowest cost sealed contactor in the industry with its current rating (500+A carry, 2000A interrupt at 320Vdc).
- Available with bottom or side mounting -- not position sensitive.
- Optional auxiliary contact for easy monitoring of power contact position.
- Hermetically sealed – intrinsically safe, operates in explosive/harsh environments with no oxidation or contamination of coils or contacts, including long periods of non-operation.
- Typical applications include battery switching and backup, DC voltage power control, circuit protection and safety.
- Versatile coil/power connections.
- Designed and built in accordance to AIAG QS9000.



For factory-direct application assistance, contact Earle Alldredge, product manager. Dial 800-253-4560, ext. 2055, or 805-220-2055. Email earle.alldredge@tycoelectronics.com



## Performance Data

Parameter	Units	Value for LEV200 Series
Contact Arrangement, power contacts		1 Form X (SPST-NO-DM)
Rated Operating Voltage	Vdc	12 - 900
Continuous (Carry) Current, Typical	A	500 @ 65°C, 400 mcm conductors <i>Consult Factory for required conductors for higher (500+ A) currents</i>
Make/Break Current at Various Voltages <sup>1/</sup>	A	See next page
Break Current at 320Vdc <sup>2/</sup>	A	2,000, 1 cycle <sup>3/</sup>
Contact Resistance, Typ. (@200A)	mohms	0.2
Load Life	Cycles	See next page
Mechanical Life	Cycles	100,000
Contact Arrangement, auxiliary contacts		1 Form A (SPST-NO)
Aux. Contact Current, Max.	A	2A @ 30Vdc / 3A @ 125Vac
Aux. Contact Current, Min.	mA	100mA @ 8V
Aux. Contact Resistance, Max.	ohms	0.417@ 30Vdc / .150 @ 125Vac
Operate Time @ 25°C		
Close (includes bounce), Typ.	ms	25
Bounce (after close only), Max.	ms	7
Release (includes arcing), Max @ 2000A	ms	12
Dielectric Withstanding Voltage	Vrms	2,200 @ sea level (leakage <1mA)
Insulation Resistance @ 500Vdc	megohms	100 <sup>2/</sup>
Shock, 11ms 1/2 sine, peak, operating	G	20
Vibration, sine, 80-2000Hz., peak	G	20
Operating Ambient Temperature	°C	-40 to +85
Weight, Typical	lb.(kg)	1.3 (.60)

<sup>1/</sup> Main power contacts

<sup>2/</sup> 50 at end of life

<sup>3/</sup> Does not meet dielectric & IR after test, 1700 amp for unit with Aux. Contacts

<sup>4/</sup> Contacts will operate with  $0.8V_{nom} < V_{coil} < 1.1V_{nom}$  over temperature range.

## Coil Data (valid over temperature range)<sup>4/</sup>

	12Vdc	24Vdc	48Vdc
Nominal Voltage	12Vdc	24Vdc	48Vdc
Pickup Voltage (will operate)	9.0Vdc	19.0Vdc	38.0Vdc
Voltage (Max.)	15Vdc	30Vdc	60Vdc
Dropout Voltage	0.75 - 2.0Vdc	1.0 - 5.0Vdc	2.0 - 7.0Vdc
Coil Resistance @ 25° (Typ.)	11 ohms	40 ohms	145 ohms

## Part Numbering System

### Typical Part Number

LEV200 A 4 N A A

### Series:

LEV200 = 500+ Amp, 12-900Vdc Contactor

### Contact Form:

A = Normally Open

H = Normally Open with Aux. Contacts. (Option "H" requires option "A" in Coil Wire Length and option "N" in Coil Terminal Connector.)

Note: Other auxiliary contact forms available. Consult factory.

### Coil Voltage:

4 = 12Vdc      5 = 24Vdc      6 = 48Vdc      K = 72Vdc  
8 = 96Vdc      L = 110Vdc      O = 115Vac      9 = 240Vac

Notes: Consult factory for detailed specifications and availability of coils not listed in "Coil Data" table above. In coil voltage codes, 115Vac is designated by the letter "O" rather than the numeral "0."

### Coil Wire Length:

A = 15.3 in (390 mm)      N = None (Requires option "A" in next step.)

### Coil Terminal Connector:

N = None, stripped wires (Requires option "A" in previous step.)

A = Studs, #10-32 Threaded (Electrical connection is made to the tab at the base of the stud.)

Note: Specify option A, stripped wires, for coil voltages > 96Vdc

### Mounting & Power Terminals:

A = Bottom Mount & Male 10mm x M8 Threaded Terminals

F = Side Mount & Male 10mm x M8 Threaded Terminals

Consult factory regarding other available mountings and power terminals.

NOTE: All part numbers are RoHS compliant (and always have been).

**KILOVAC LEV200 Series** (Continued)

**Outline Dimensions**

**Side Mount Enclosure**

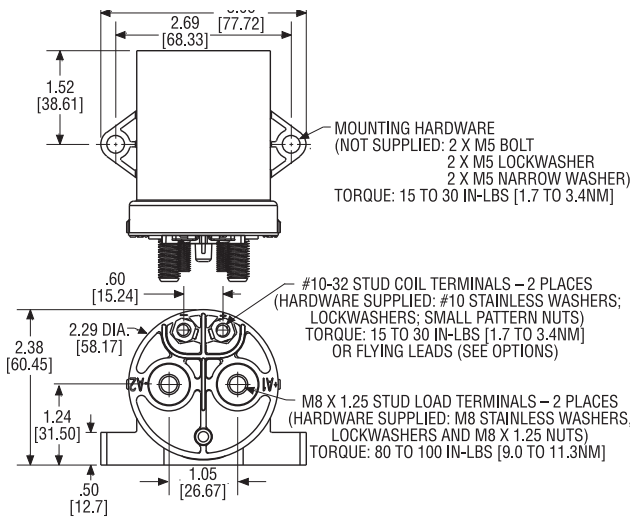

NOTE: When stud terminals are specified for coil connections, the electrical connection is made at the tab located at the base of the stud.

**Bottom Mount Enclosure**

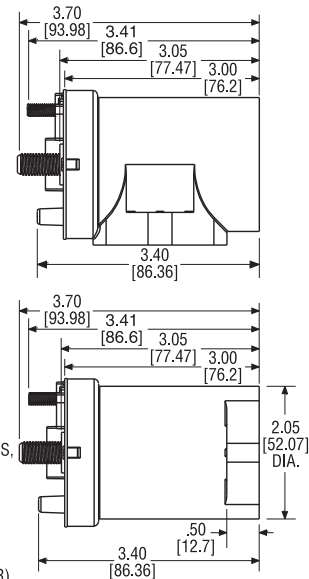
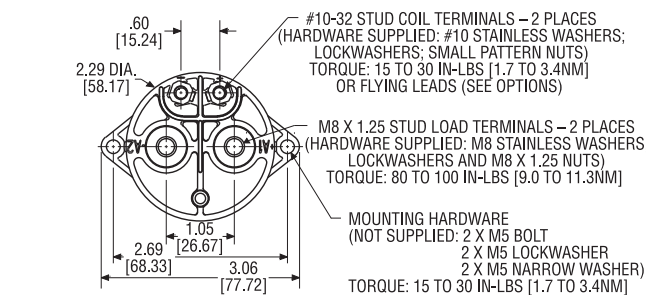

**Estimated Make & Break Power Switching Ratings**

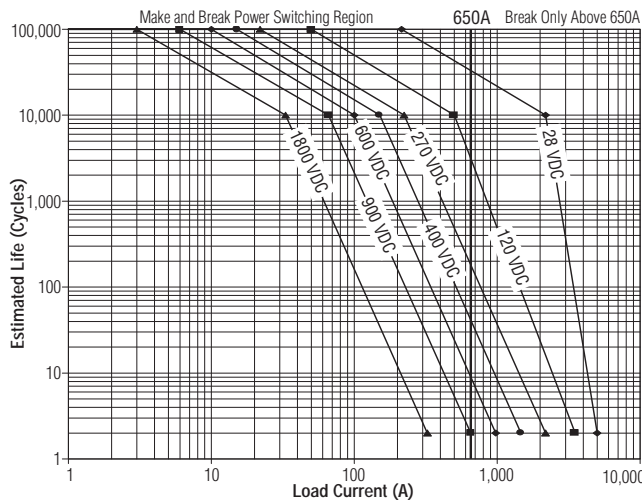

- NOTES:  
1) For resistive loads with 300µH maximum inductance. Consult factory for inductive loads.  
2) Estimates based on extrapolated data. User is encouraged to confirm performance in application.  
3) End of life when dielectric strength between terminals falls below 50 megohms @ 500VDC.  
4) The maximum make current is 650A to avoid contact welding.

**Electrical Load Life Ratings for Typical LEV Applications**

Make/Break Life Capacitive & Resistive Loads at 320VDC (1) (2)	
@90% capacitive pre-charge (make only) see chart below	Cycles 50,000
@80% capacitive pre-charge (make only) see chart below	Cycles 50
2,000A (break only) (1)	Cycles 1*
<b>Mechanical Life</b>	<b>Cycles 100,000</b>

- (1) Resistive load includes inductance L = 25µH. Load @ 2500A tested @ 200µH.  
(2) Life based on projected Weibull Life with 95% reliability.  
\* Does not meet dielectric and IR after test.

**LEV200 Capacitive Make Test Curves for Pre-Charged Motor Controller**

